

Model

Designation	SC18CL	220-240V/50Hz 1~	Sales code:	104L2123
-------------	---------------	-------------------------	-------------	-----------------

Compressor design

Oil type	Polyolester	Refrigerant(s)	R404A, R452A, R507
Oil viscosity	32cSt	Displacement	17,69cm ³ / 1,08cu.in
Oil quantity	594cm ³ / 20,1fl.oz	Compressors on pallet	80
Refr. charge - tech. limit	1300g / 45,9oz		
Free gas volume comp.	1460cm ³ / 49,4fl.oz		
Weight	13,8kg / 30,4lbs		
Motor protection	1# internal		
Winding resistance main	3,7Ω (at 25°C)		
Winding resistance aux	14Ω (at 25°C)		
Max. winding temp.	125°C / 257°F		
Max. discharge temp.	130°C / 266°F		



General - Configurations with SC18CL

	Conf. 1	Conf. 2
Motorconfiguration	CSCR	CSCR
Power supply (nominal)	220-240V/50Hz	220-240V/50Hz
Number of phases	1	1
Voltage range	198-254V	198-254V
Approvals	VDE, CCC, EAC	VDE, CCC
Starting torque	HST	HST
Note	- / -	

Applications with SC18CL

	Conf. 1	Conf. 2
Refrigerant	R404A	R452A
Application	LBP+MBP	LBP+MBP
System cooling	fan 3m/s	fan 3m/s
Hot gas defrost	OK	OK
Long interval pull down	OK	OK

Electrical data - Configurations with SC18CL

	Conf. 1	Conf. 2
Starting device type	relay	relay
Run capacitor	10μF	10μF
Start capacitor	80μF	80μF
LRA (locked rotor amps / 4s)	20,43A	20,43A
RLA (rated load amps / 1s)	4,2A	4,2A
Cut in current	20,43A	20,43A
IP class	21	21

Model

Designation	SC18CL	220-240V/50Hz 1~	Sales code:	104L2123
-------------	---------------	-------------------------	-------------	-----------------

Compressor dimensions

Housing	A Height	219mm / 8,62in
	B Height	213mm / 8,39in
	C Length shell	218mm / 8,58in
	D Length w. cover	255mm / 10,04in
	E Width	151mm / 5,94in

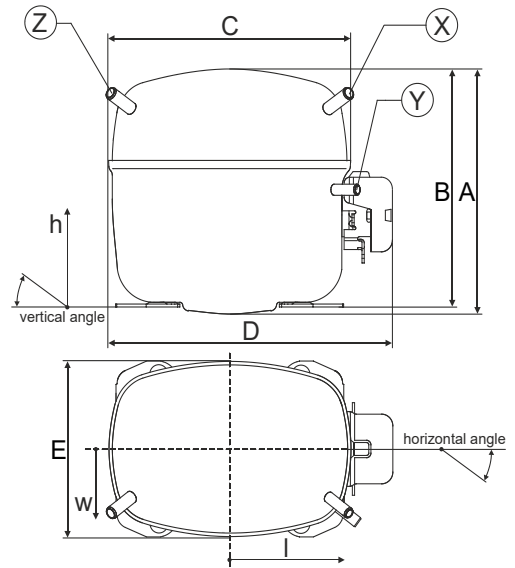

Connectors	Suction		Discharge		Process	
	X		Y		Z	
Diameter [mm]	øi 10,11-10,29		øi 6,11-6,29		øi 6,11-6,29	
(i:inside, o:outside) [in]	øi 0,4-0,41		øi 0,24-0,25		øi 0,24-0,25	
Material	copper		copper		copper	
Horizontal angle ±2°	37°		37°		143°	
Vertical angle ±2°	30°		0°		150°	
Position l/h/w [mm]	107/193/55		115/110/63		-107/193/55	
[in]	4,2/7,6/2,2		4,5/4,3/2,5		-4,2/7,6/2,2	
Straight tube l.	[mm]		12		12	
	[in]		0,5		0,5	

Compressor fixation

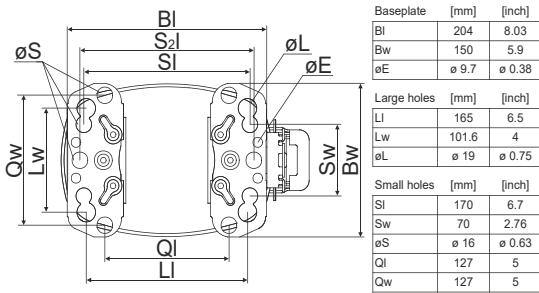

Baseplate	[mm]	[inch]
BI	204	8.03
Bw	150	5.9
øE	ø 9.7	ø 0.38
Large holes		
LI	165	6.5
Lw	101.6	4
øL	ø 19	ø 0.75
Small holes		
SI	170	6.7
Sw	70	2.76
øS	ø 16	ø 0.63
QI	127	5
Qw	127	5

Bolt joint

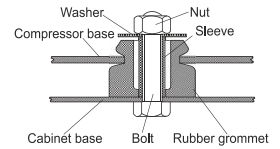

Snap-on

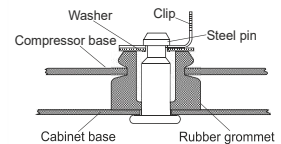

Mounting accessories	one comp.	multi pack
Bolt joint M6 ø16mm	118-1917	118-1918
Bolt joint ø1/4" ø16mm	118-1946	
Bolt joint ø1/4" ø19mm	118-1949	
Snap-on ø7,3 ø16mm	118-1947	118-1919

Model

Designation	SC18CL	220-240V/50Hz	Conf. 1	Sales code:	104L2123
-------------	---------------	----------------------	----------------	-------------	-----------------

Configuration

Motorconfiguration	CSCR
Power supply (nominal)	220-240V/50Hz 1~
Refrigerant	R404A
Application	LBP+MBP
Voltage range	198-254V
Starting torque	HST
Approvals	VDE
	CCC
	EAC

Electrical accessories / wiring diagram

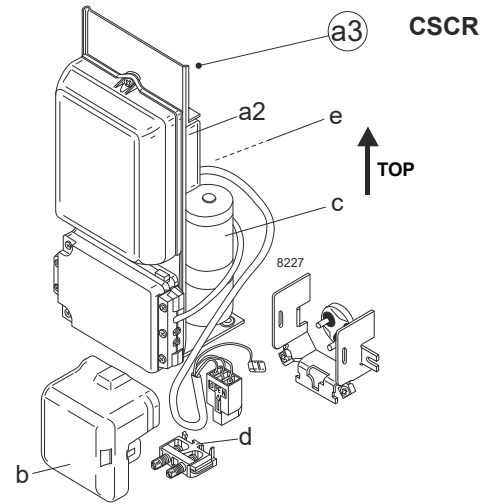

Ambient temperatures / system cooling

Ambient temperature min.:	10°C / 50°F
Ambient temperature max.:	38°C / 101°F

System cooling (n/a: outside limits)			
T ambient	LBP	MBP	HBP
32°C / 90°F	fan 3m/s	fan 3m/s	n/a
38°C / 100°F	fan 3m/s	fan 3m/s	n/a
43°C / 110°F	n/a	n/a	n/a

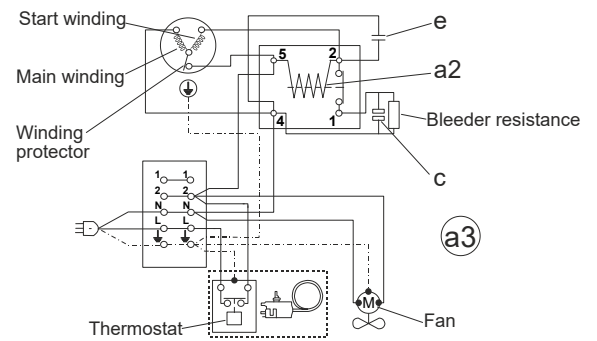

Operation pressure range

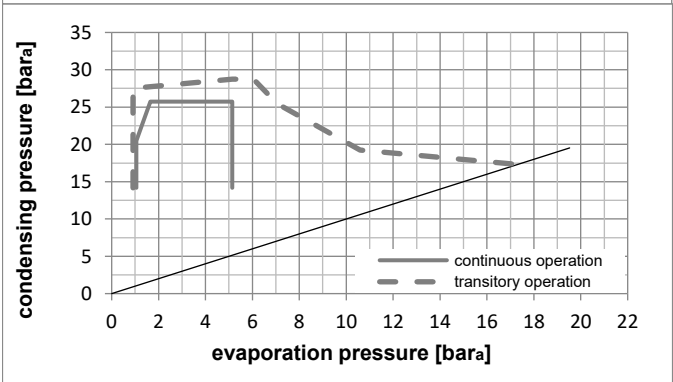
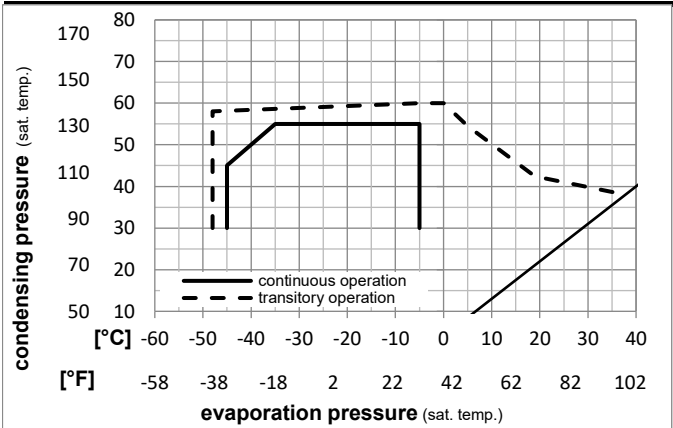

Components

a3	SC starter kit (550mm)	117-7027
b	plastic cover	103N2009
d	cord relief	103N1004

Alternative components

a3	SC starter kit (1000mm)	117-7040
a3	SC starter kit (650mm)	117-7046

Model

Designation **SC18CL 220-240V/50Hz** Conf. 1 Sales code: **104L2123**

Optimization + standard conditions

220V/50Hz, CSCR, fan 3m/s, VDE, CCC, EAC

	Evaporating pressure (saturation temperature)				Condensing pressure (saturation temperature)						Power consumption			ASHRAE LBP
	pe	pc	RGT	Tliq	Cooling capacity			COP	EER	P1	I	Ref. mass flow		
	[°C]	[°C]	[°C]	[°C]	[W]	[Btu/h]	[kcal/h]	[W/W]	[Btu/Wh]	[kcal/Wh]	[W]	[A]	[kg/h]	
	-23,3	54,4	32,2	32,2	800,9	2735	689,3	1,21	4,14	1,04	660,0	3,78	18,66	ASHRAE LBP
	[-10]	130	90	90										
	-25	55	32	55	538,7	1840	463,6	0,86	2,92	0,74	629,0	3,65	16,83	cecomaf LBP
	[-13]	131	89,6	131										
	-35	40	20	40	436,2	1490	375,4	0,97	3,30	0,83	451,0	3,01	11,85	EN12900 LBP
	[-31]	104	68	104										
	-6,66	54,4	35	46,1	1510,0	5157	1299,5	1,50	5,11	1,29	1009,3	5,33	41,55	ASHRAE MBP
	[20]	130	95	115										
	-10	55	32	55	1123,6	3837	967,0	1,20	4,11	1,04	933,1	4,99	35,97	cecomaf MBP
	[14]	131	89,6	131										
	-10	45	20	45	1342,7	4585	1155,5	1,50	5,13	1,29	894,0	4,80	40,44	EN12900 MBP
	[14]	113	68	113										

Performance tables

220V/50Hz, CSCR, fan 3m/s, VDE, CCC, EAC

	pe	Cooling capacity			COP	EER	P1	I	m		
	[°C]	[°F]	[W]	[Btu/h]	[kcal/h]	[W/W]	[Btu/Wh]	[kcal/Wh]	[W]	[A]	[kg/h]
[°C / °F]	-45	-49	166,7	569	143,5	0,57	1,94	0,49	293,6	2,61	4,43
cond. pressure	-35	-31	394,5	1347	339,6	0,87	2,96	0,75	455,2	3,02	10,55
pc= 45/113	-30	-22	541,8	1850	466,3	1,01	3,47	0,87	534,0	3,29	14,54
return gas temp.	-25	-13	715,3	2443	615,6	1,16	3,97	1,00	614,8	3,60	19,30
RGT= 32/90	-20	-4	918,3	3136	790,3	1,31	4,48	1,13	700,1	3,96	24,92
liquid temp	-15	5	1153,9	3941	993,0	1,46	4,97	1,25	792,3	4,36	31,52
Tliq= 45/113	-5	23	1734,8	5925	1493,0	1,72	5,88	1,48	1007,6	5,29	48,23
[°C / °F]	-45	-49	83,9	286	72,2	0,33	1,14	0,29	252,2	2,47	2,58
cond. pressure	-35	-31	275,1	940	236,8	0,62	2,11	0,53	444,8	2,97	8,51
pc= 55/131	-30	-22	396,3	1353	341,1	0,74	2,52	0,64	536,7	3,29	12,32
return gas temp	-25	-13	538,7	1840	463,6	0,86	2,92	0,74	629,0	3,65	16,83
RGT= 32/90	-20	-4	705,3	2409	606,9	0,97	3,33	0,84	724,2	4,05	22,19
liquid temp	-15	5	899,2	3071	773,9	1,09	3,72	0,94	824,7	4,50	28,52
Tliq= 55/131	-5	23	1381,5	4718	1188,9	1,31	4,49	1,13	1051,7	5,52	44,72

Model

Designation	SC18CL	220-240V/50Hz	Conf. 2	Sales code:	104L2123
-------------	---------------	----------------------	----------------	-------------	-----------------

Configuration

Motorconfiguration	CSCR
Power supply (nominal)	220-240V/50Hz 1~
Refrigerant	R452A
Application	LBP+MBP
Voltage range	198-254V
Starting torque	HST
Approvals	VDE
	CCC

Electrical accessories / wiring diagram

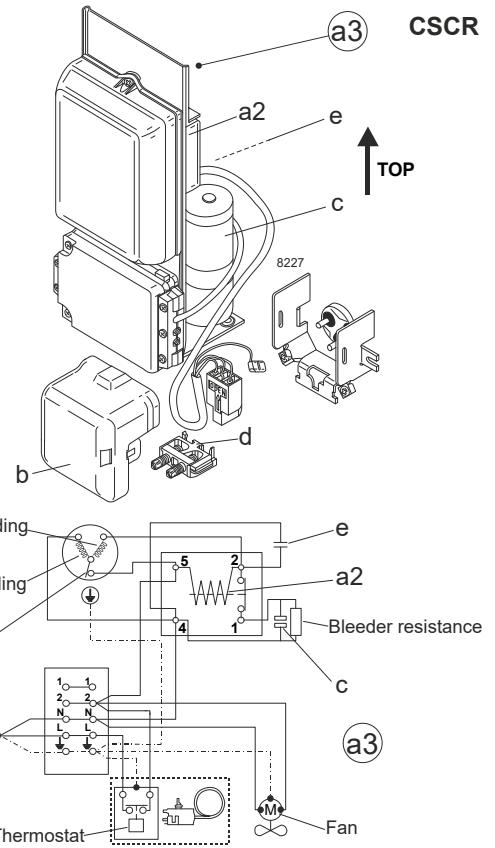

Ambient temperatures / system cooling

Ambient temperature min.:	10°C / 50°F
Ambient temperature max.:	38°C / 101°F

System cooling (n/a: outside limits)			
T ambient	LBP	MBP	HBP
32°C / 90°F	fan 3m/s	fan 3m/s	n/a
38°C / 100°F	fan 3m/s	fan 3m/s	n/a
43°C / 110°F	n/a	n/a	n/a

Operation pressure range

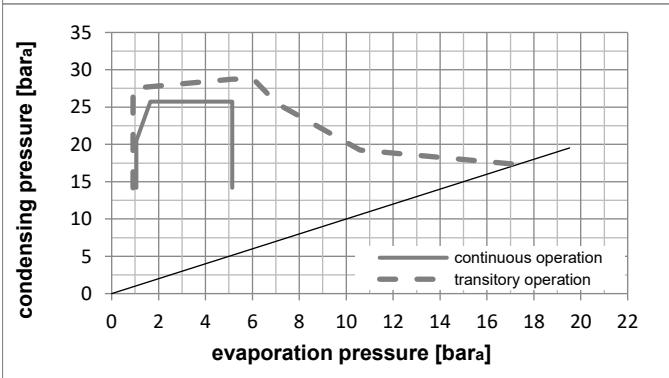
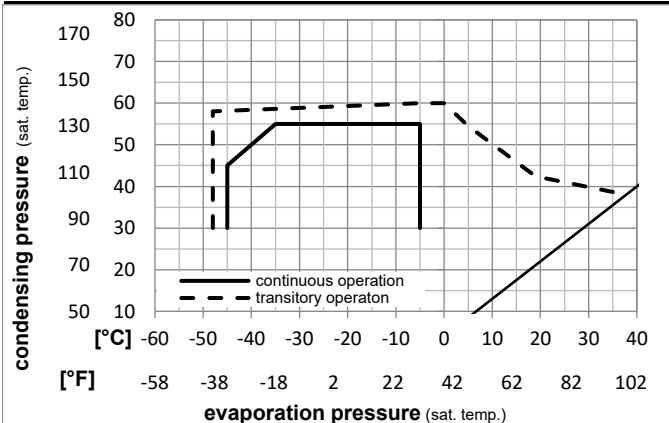

Components

a3	SC starter kit (550mm)	117-7027
b	plastic cover	103N2009
d	cord relief	103N1004

Alternative components

a3	SC starter kit (1000mm)	117-7040
a3	SC starter kit (650mm)	117-7046

Model

Designation **SC18CL 220-240V/50Hz** Conf. **2** Sales code: **104L2123**

Optimization + standard conditions

220V/50Hz, CSCR, fan 3m/s, VDE, CCC

	Evaporating pressure (saturation temperature)				Condensing pressure (saturation temperature)						Power consumption			ASHRAE LBP
	pe	pc	RGT	Tliq	Cooling capacity			COP	EER	P1	I	Ref. mass flow		
	[°C]	[°C]	[°C]	[°C]	[W]	[Btu/h]	[kcal/h]	[W/W]	[Btu/Wh]	[kcal/Wh]	[W]	[A]	[kg/h]	
	-23,3	54,4	32,2	32,2	732,0	2500	630,0	1,19	4,07	1,03	613,6	2,95	17,59	ASHRAE LBP
	[-10]	130	90	90										
	-25	55	32	55	496,2	1695	427,1	0,85	2,91	0,73	583,1	2,83	15,79	cecomaf LBP
	[-13]	131	89,6	131										
	-35	40	20	40	393,1	1342	338,3	0,95	3,24	0,82	414,5	2,13	10,98	EN12900 LBP
	[-31]	104	68	104										
	-6,66	54,4	35	46,1	1429,2	4881	1230,0	1,49	5,09	1,28	958,1	4,48	40,21	ASHRAE MBP
	[20]	130	95	115										
	-10	55	32	55	1065,1	3637	916,6	1,21	4,12	1,04	882,4	4,11	34,62	cecomaf MBP
	[14]	131	89,6	131										
	-10	45	20	45	1268,5	4332	1091,7	1,50	5,12	1,29	845,9	3,95	38,98	EN12900 MBP
	[14]	113	68	113										

Performance tables

220V/50Hz, CSCR, fan 3m/s, VDE, CCC

	pe	Cooling capacity			COP	EER	P1	I	m		
	[°C]	[°F]	[W]	[Btu/h]	[kcal/h]	[W/W]	[Btu/Wh]	[kcal/Wh]	[W]	[A]	[kg/h]
[°C / °F]	-45	-49	140,1	478	120,5	0,54	1,85	0,47	258,3	1,38	3,82
cond. pressure	-35	-31	354,2	1210	304,9	0,85	2,90	0,73	416,7	2,16	9,72
pc= 45/113	-30	-22	493,5	1686	424,7	1,00	3,41	0,86	493,6	2,49	13,59
return gas temp.	-25	-13	658,8	2250	567,0	1,15	3,93	0,99	572,5	2,81	18,23
RGT= 32/90	-20	-4	853,5	2915	734,5	1,30	4,45	1,12	655,7	3,14	23,73
liquid temp	-15	5	1080,8	3691	930,1	1,45	4,95	1,25	746,0	3,52	30,23
Tliq= 45/113	-5	23	1647,0	5625	1417,4	1,72	5,87	1,48	957,9	4,48	46,80
[°C / °F]	-45	-49	64,7	221	55,7	0,30	1,03	0,26	213,8	1,27	2,03
cond. pressure	-35	-31	245,0	837	210,8	0,61	2,08	0,52	402,7	2,11	7,73
pc= 55/131	-30	-22	360,1	1230	309,9	0,73	2,50	0,63	492,7	2,47	11,40
return gas temp	-25	-13	496,2	1695	427,1	0,85	2,91	0,73	583,1	2,83	15,79
RGT= 32/90	-20	-4	656,9	2243	565,3	0,97	3,32	0,84	676,5	3,20	21,03
liquid temp	-15	5	845,4	2887	727,5	1,09	3,72	0,94	775,4	3,62	27,25
Tliq= 55/131	-5	23	1319,3	4506	1135,4	1,32	4,50	1,14	1000,2	4,69	43,30